

CASE REPORTS

Spontaneous fulminant gas gangrene

M S Delbridge, E P L Turton, R C Kester

Emerg Med J 2005;22:520–521. doi: 10.1136/emj.2003.013144

Gas gangrene is a rare condition, usually associated with contaminated traumatic injuries. It carries a high rate of mortality and morbidity. A number of studies have implicated non-traumatic gas gangrene and colonic neoplasia. This paper reports a patient who presented spontaneously with *Clostridium septicum* gas gangrene and an occult caecal carcinoma.

A previously healthy, non-diabetic, 82 year old man was admitted to York District Hospital complaining of pain and swelling of the right arm. He attributed this to a trivial injury sustained to his arm on a supermarket shelf earlier that day. At approximately 6 30 pm on the same day his wife noticed what appeared to be a bruise over the upper arm with small areas of blistering. He was admitted to York District Hospital later that evening by which time the entire right upper limb had become tense and swollen upto the level of the neck; the skin was dusky purple and cyanosed, and there were a number of haemorrhagic bullae.

On examination he appeared pale and distressed but was alert and cooperative. Inspection of the upper limb revealed diffuse crepitus and absent distal pulses, both on palpation and Doppler. Vital signs were as follows: pulse 100 per minute, blood pressure (BP) 100/60 mm Hg, temperature 36.7 °C. Abnormal laboratory results included low plasma sodium levels (127 mmol/l; hyponatraemia), raised urea and creatinine (7.3 mmol/l and 186 µmol/l, respectively) and raised plasma glucose level (24.6 mmol/l; hyperglycaemia). A chest x ray confirmed the presence of diffuse surgical emphysema (fig 1).

The patient was catheterised and given 1.5 g cefuroxime, 500 mg metronidazole, and 600 mg benzylpenicillin; in addition he received opiate analgesia and 1 l of succinylated gelatin (Gelofusine; B Braun Medical, UK).

Early next morning he was transferred to St James University Hospital. On arrival at 8 15 am he remained afebrile and was still cardiovascularly stable. However, it was clear that he had deteriorated severely—he was confused, agitated, and tachypnoeic. The blistering and discoloration had spread across his chest wall, neck, back, and abdomen. His vital signs at this point were as follows: urine output 30 ml/h, pulse 100 per minute, BP 120/70 mm Hg and temperature 36 °C. Additional laboratory results demonstrated metabolic acidosis (HCO_3^- 16.3 mmol/l and pH 7.28).

We sought advice about management of the patient from both a microbiologist and a plastic surgeon, but it was deemed that radical debridement would be of little use at this stage and any treatment would be palliative. At 9 am he was intubated and ventilated and an internal jugular central line inserted. He was given 100 ml 20% mannitol, 50 ml 8.4% HCO_3^- and 1 l 0.9% NaCl; in addition we carried out multiple fasciotomies in an attempt to improve circulation in the upper limb (fig 2).



Figure 1 Chest x ray: note the diffuse surgical emphysema over the chest wall.

The patient had a cardiac arrest at 9 30 am and was successfully revived, but unfortunately he had a second arrest and resuscitation was unsuccessful. He was declared dead at 10 50 am.

A diagnosis of arterial vascular occlusion secondary to gas gangrene was made which was confirmed by post mortem. Microbiological examination revealed Gram-positive bacilli and culture demonstrated profuse *C. septicum* infection. The post mortem declared the cause of death to be acute myocardial ischaemia, but a major contributing factor was the gross infection of the upper limb; an additional finding



Figure 2 Areas of dusky discoloration and haemorrhagic bullae can be seen. Note also the fasciotomy incisions and the marker line on the chest indicating the rapidity of the spreading infection.

was a small caecal carcinoma with a 4 cm metastatic deposit in the right lobe of the liver.

DISCUSSION

Gas gangrene is a condition of rapidly developing and spreading infection mediated by toxins released by the bacteria *Clostridium* spp. It is most often associated with traumatic injuries. *C. perfringens* is the commonest species, followed by *C. novyi*. *C. septicum* is relatively uncommon, and it is estimated to be the cause of only 1.3% of all clostridial infections.¹⁻³ *C. septicum* represents a novel subtype among clostridial species, with several notable differences. It is able to cause devastating tissue necrosis in the absence of prior trauma,^{1-3,6} and is able to present distant from the presumed portal of entry resulting in metastatic myonecrosis.^{4,5}

Clostridial infections are believed to have a greater prevalence among individuals who have malignant disease.¹⁻⁶ Larson *et al*, in a series of 241 patients with clostridial infection, found 10% had an associated malignancy.⁵ However, when *C. septicum* infections were considered alone the incidence of associated malignancy was 52.6%.⁶ In a further study of patients with *C. septicum* infection, conducted between 1966 and 1993, 50% had a primary malignancy, 75% of which were colonic, of these 40% were caecal.⁵

Few patients presenting with *C. septicum* infection have a history of prior trauma.¹⁻⁶ Several papers have suggested that mucosal ulceration of the tumour surface and haematogenous invasion allow a portal of entry for the bacteria, thus explaining the low incidence of antecedent trauma.⁷⁻⁹ The theory of mucosal ulceration as the portal of entry is supported by the case reported by Abella *et al* in which a patient with radiation colitis had spontaneous *C. septicum* gas gangrene.¹

Our case illustrates the fulminant nature of gas gangrene and although it is an uncommon diagnosis, it is essential that the management be initiated early. This should include

aggressive resuscitation, early antibiotics, hyperbaric oxygen therapy (although this has never been subjected to a controlled trial and unless it is readily available it would seem to present a potentially fatal delay), and radical surgical debridement.

Authors' affiliations

M S Delbridge, E P L Turton, R C Kester, Department of Vascular and Endovascular Surgery, St James University Hospital, Leeds, West Yorkshire, UK

Competing interests: none declared

Correspondence to: M Delbridge, Northern General Hospital, Sheffield, UK; janeandmike1@aol.com

Accepted 5 February 2004

REFERENCES

- 1 **Abella BS**, Kuchinic P, Hiraoka T, *et al*. A traumatic clostridial myonecrosis: case report and literature review. *J Emerg Med* 2003;**24**:401-5.
- 2 **Lamb RC**, Hart GB, Strauss MB. Gas gangrene: a collective review. *J Trauma* 1983;**23**:991-5.
- 3 **Larson HE**. Botulism, gas gangrene and clostridial gastrointestinal infections. In: Warrell DA, Cox TM, Firth JD, eds. *Oxford Textbook of Medicine*, 4th edn. Oxford: University Press, 2003:555-6.
- 4 **Lorimer JW**, Eids LB. Clostridium septicum in association with colorectal cancer. *Can J Surg* 1994;**37**:245-8.
- 5 **Larson CM**, Bublick MP, Jacobs MD, *et al*. Diffuse spreading Clostridium septicum infection, malignant disease and immune suppression. *Surg Gynecol Obstet* 1998;**166**:197-9.
- 6 **Kirchner JT**. Clostridium septicum infection. Beware of associated cancer. *Postgrad Med* 1991;**90**:157-60.
- 7 **Draser BS**, Goddard P, Heaton S, *et al*. Clostridium isolated from faeces. *J Med Microbiol* 1976;**9**:63-71.
- 8 **Kudsk KA**. Occult gastrointestinal malignancies producing metastatic Clostridium septicum infections in diabetic patients. *Surgery* 1992;**112**:765-70.
- 9 **Malmgren RA**, Flanigan CC. Localisation of the vegetative form of Clostridium tetani in mouse tumours following IV spore administration. *Cancer Res* 1955;**15**:473-78.

Delayed presentation of traumatic ventricular septal defect and mitral leaflet perforation

J A Vecht, M F Ibrahim, A O Chukwemeka, P R James, G E Venn

Emerg Med J 2005;**22**:521-522

A case of intracardiac stabbing is reported. The victim sustained injuries disproportionate to his initial presentation. These included a ventricular septal defect and mitral valve leaflet perforation. The need for immediate referral to a cardiothoracic unit and the importance of the use of echocardiography is stressed. This enables the safest and most appropriate management of potentially lethal injuries.

We report the case of a 48 year old man who presented to his local A&E department following a stab injury to the right inferior parasternal area at the fourth intercostal space. He had been assaulted earlier in the day during an argument. On presentation he was slightly drowsy and complained of chest and upper abdominal pain. He was

tachypnoeic and had a sinus tachycardia of 110 beats/min. His blood pressure was 100/60 mm Hg. Abdominal examination showed rigidity and guarding in the right upper quadrant. A chest radiograph showed a questionable widening of his mediastinum, and transthoracic echocardiography suggested a small anterior pericardial effusion with a mass consistent with thrombus on the anterior surface of the heart. He subsequently suffered an asystolic cardiac arrest and cardiopulmonary resuscitation was started. Emergency pericardiocentesis yielded 20 ml of dark blood and he was taken directly to the operating theatre at the referring district general hospital.

An emergency laparotomy and median sternotomy were carried out and a direct puncture to the anterior surface of the heart (presumed to be the right atrium) was identified. This was repaired with prolene sutures and the thrombus within the pericardial space was evacuated. Postoperatively,

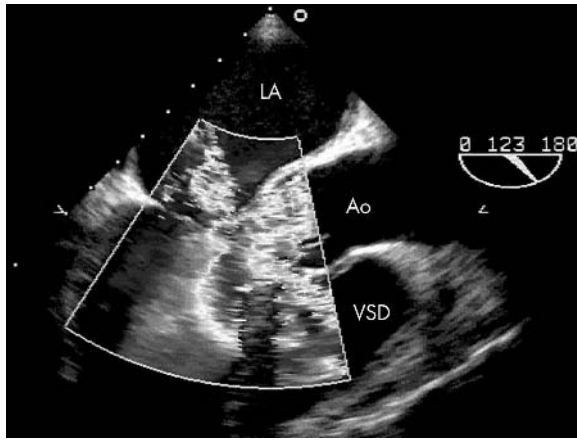

Figure 1 A transoesophageal echocardiographic image showing the two abnormal flow jets in systole—through the anterior mitral valve leaflet and the VSD—in line with the passage of the knife.

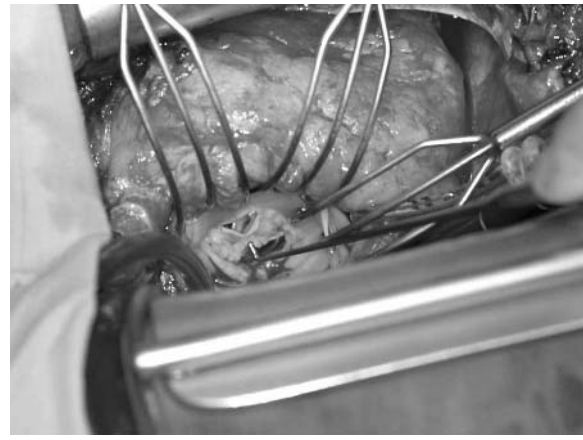

Figure 2 Intraoperative photograph showing a probe placed within the perforation of the anterior mitral valve leaflet.

the patient remained on the intensive care unit (ICU) where he developed a left sided pneumonia and signs consistent with adult respiratory distress syndrome. A transthoracic echocardiogram at this time was reported as normal. The patient gradually deteriorated and by day 10 he had developed florid pulmonary oedema and haemoptysis. In addition, a new systolic murmur was reported. Repeat transthoracic echocardiography showed significant mitral regurgitation with a subaortic ventricular septal defect (VSD).

Following transfer to the St Thomas' Hospital Cardiothoracic Centre, an emergency transoesophageal echocardiogram showed a tear in the anterior leaflet of the mitral valve, with severe regurgitation, and confirmed the VSD (fig 1). The patient was taken directly to the operating theatre where cardiopulmonary bypass was established, and the mitral valve was exposed through a Guiraudon incision which passed through the right atrium and across the atrial septum to enter the left atrium. The knife had entered the right ventricular wall, penetrated the ventricular septum (causing the VSD) and had lacerated the anterior mitral valve leaflet. The middle scallop of the anterior leaflet of the mitral valve was found to be detached (fig 2). The valve was repaired with interrupted 2-0 ethibond sutures and the insertion of a 28 mm Cosgrove-Edwards annuloplasty band. The subvalvar VSD beneath the right coronary cusp of the aortic valve was repaired using interrupted ethibond sutures.

The patient was discharged from the ITU after one day, was successfully rehabilitated, and was discharged from hospital after three weeks. Postoperative transthoracic echocardiography, done immediately before discharge from hospital, showed only mild transvalvar mitral regurgitation and no residual flow at the site of the VSD repair.

DISCUSSION

There are examples of traumatic ventricular septal defects with associated mitral valve damage in the medical literature but they are uncommon.^{1,2} The rate of cardiac stabbings is increasing in the United Kingdom, so awareness of this condition is becoming more important. The importance of this case is that the full extent of the cardiac injury was not revealed until late. Initial echocardiographic findings were

normal, but repeated investigations showed gross pathology. Similar findings have been described by Thandroyen and Mattison, who proposed that penetrating cardiac injury creates an intracardiac fistula which enlarges over time.³ In addition, it is postulated that thrombus formation or muscular spasm may initially seal small cardiac wounds. Such a mechanism may explain the delayed presentation which occurred in this case.

There are many published reports of traumatic VSDs but fewer reports of VSDs with associated mitral leaflet damage as a result of trauma, particularly stabbing.^{1,2} Even in the absence of cardiac tamponade, significant intracardiac trauma may have occurred.¹ In the management of penetrating thoracic injuries it is important not to underestimate the full extent of potential injuries, which may often be greater than the inlet and exit injuries suggest. Careful consideration of the likely anatomical pathway, in accordance with the length of stabbing implement, aided by directed echocardiography are essential features of the management of such injuries. A high index of suspicion and repeated re-examination of the patient are important, and early liaison with a cardiothoracic centre is recommended.

Authors' affiliations

J A Vecht, M F Ibrahim, A O Chukwuemeka, P R James, G E Venn, Department of Cardiothoracic Surgery, St Thomas' Hospital, London SE1, UK

Correspondence to: Andrew Chukwuemeka, Department of Cardiothoracic Surgery, St Thomas' Hospital, London SE1 7EH, UK; andrew.chukwuemeka@gstt.sthames.nhs.uk

Accepted for publication 27 August 2003

REFERENCES

- 1 Pasteuning WH, Wonnink-de Jonge WF, van Berge Henegouwen DP, et al. Acquired ventricular septal defect and mitral insufficiency without pericardial effusion after stab wound to chest. *J Am Soc Echocardiogr* 1998;11:483-6.
- 2 Hines GL, Doyle E, Acinapura AJ. Post-traumatic ventricular septal defect, mitral insufficiency and multiple coronary cameral fistulas. *J Trauma* 1977;17:234-7.
- 3 Thandroyen FT, Mattison RE. Penetrating thoracic trauma producing cardiac shunts. *J Thorac Cardiovasc Surg* 1981;81:569.

Rectus sheath haematoma: 'a diagnostic dilemma ?'

J Costello, J Wright

Emerg Med J 2005;22:523–524. doi: 10.1136/emj.2004.015834

Rectus Sheath Haematoma is a relatively rare presentation in the context of acute Accident and Emergency presentations. Correct diagnosis and subsequent management depend on sound clinical acumen and history taking with appropriate use of diagnostic aides in order to avoid prolonged and inappropriate management of such cases. We present an interesting case of a young fit male whose history alone suggested the diagnosis despite an initial diagnostic dilemma.

CASE REPORT

A fit 18 year old male rugby player presented to Accident and Emergency Department with a 4 hour history of acute onset progressive right lower quadrant abdominal pain. Such pain, described as sharp in nature and exacerbated by pelvic movement and coughing, was initially noticed during a rigorous exercise programme on a rowing machine. He was normotensive, afebrile with a pulse rate of 86 bpm (average).

Examination revealed quite a marked degree of abdominal guarding and rigidity particularly in the right lower quadrant. Nothing else remarkable was in evidence on further examination. Subsequent investigation revealed normal Fbc, Bioprofile, and plain radiographic studies of the abdomen. The patient remained in extremis and treated accordingly with incremental doses of intravenous opiate analgesia. A provisional diagnosis of acute appendicitis was made and admission arranged for surgical management.

Despite refractory presentation a decision was made to continue with supportive symptomatic management. The patient showed symptomatic improvement with conservative management (intravenous fluids and analgesia).

'Next-day' ultrasound abdomen revealed a large Rectus Sheath Haematoma. The patient quickly improved and was discharged the following day on oral analgesia as required.

Appropriate advice was issued regarding sports, exercise, and training.

DISCUSSION

Rectus Sheath Haematoma, as an acute abdominal presentation,¹ is relatively uncommon. Reported rates vary,² but current literature suggests a female:male preponderance of 2–3:1 in the 50 to 60 year old age group (however, equal distribution in the younger age groups is noted despite different aetiology). Overall incidence is not quantified owing to rarity of presentation.

Rectus Sheath Haematoma is an accumulation of blood in the anterior Rectus abdominis muscle. Primary causation is due to either epigastric vessel rupture or muscle body tear. This may occur in any abdominal quadrant but typically sub-umbilical due to Rectus Abdominis *posterior wall supportive deficit* below the level of the linea semilunaris (weak transversalis fascia and peritoneum being the essential supportive framework for Rectus Abdominis) and *relative infrastructural rigidity* (firm adherence of inferior epigastric penetration arteries to rectus abdominis). As in our case, intense, perhaps unaccustomed, muscular exertion induced labile contractile muscle lengths and *shear forces* in a plane

opposite to epigastric penetration vessels resulting in immediate haematoma formation.

Predisposing factors associated with Rectus Sheath Haematoma formation are varied and include hypertension, arteriosclerosis, old age, obesity, direct abdominal trauma, anticoagulant therapy, previous abdominal surgery, pregnancy and acute intra-abdominal pressure fluctuations (straining, coughing, exertion) – the latter illustrating male predominance, as in our index case.

Interestingly, one series reported a case related to intramuscular administration of low molecular weight subcutaneous heparin.³

Clinical presentation is often non-specific⁵ – pain and swelling/mass in any one of the four abdominal quadrants (left upper quadrant being the site of least frequency in reported series) – typically the lower quadrants being the sites of most frequent occurrence.⁴ Pain, often in isolation of mass/swelling, is usually of acute onset, of moderate severity with signs suggestive of peritoneal irritation. The presence of an associated mass is often highly suggestive, particularly if right sided and is considered diagnostic if extends to midline. Some series⁶ have quoted associated signs – notably *Fothergill's Grey Turner's*, *Cullen's*, and dysuria/urinary frequency – depending on breach of peritoneum but these are typically associated with delayed presentation beyond 48 hours.

Supportive data may occasionally include a mild leucocytosis, a low grade pyrexia or a corroborative drop in haemoglobin (clearly extent related), however, these are considered unusual.

Diagnostic conclusion is usually successful with a combination of clinical awareness and radiographic imaging – Ultrasound or Computed Tomography. Ultrasound is usually the investigation of choice due to high sensitivity rates (approaching 100% in most series), time/cost efficacy and radiation safety protocol. Classical ultrasonographic appearances range from sonolucent (early stage) to sonodense (late stage) appearance with time from initial injury.

Computed Tomography is considered more sensitive an investigation and useful in cases of inconclusive ultrasound but due to issues relating to time/resource management is less commonly employed. Magnetic Resonance Imaging has been less employed and is considered as sensitive as the aforementioned. Should the diagnosis continue to prove elusive, more invasive methods such as diagnostic needle aspiration and laparotomy have been suggested, however, the former has not received much acclaim due to reasons relating to sepsis propagation.¹

A conservative non interventional approach to diagnosis/management has received acceptance most recently. Such approach, of course, advocates analgesia, serial clinical assessment, bedrest, haematoma compression, icepack application, and managing the predisposing cause. Clearly, haemodynamic compromise necessitates operative intervention - clot evacuation and vessel ligation via laparotomy or laparoscopic⁶ approach is usual. Levy *et al*⁷ reported successful interventional outcome with *Gelfoam embolization* however this method has not received much acclaim.

Rectus Sheath Haematoma may prove to be a diagnostic dilemma; differential diagnoses would have to include ovarian pathology (torsion, cyst), appendicitis, intestinal pathology (obstruction, neoplasia, perforation) and strangulated herniae.

As our case demonstrates, reasonable prolonged conservative management (in the context of clinical awareness and corroborative diagnostic exclusion) should negate the need for intervention in the case of Rectus Sheath Haematoma assuming haemodynamic stability.

Authors' affiliations

J Costello, J Wright, Department of Accident & Emergency Medicine, Newcastle General Hospital, Newcastle upon Tyne, NE4 6AB

Correspondence to: J Costello, Department of Accident & Emergency Medicine, Newcastle General Hospital, Newcastle upon Tyne, NE4 6AB; jonathancostelloe@hotmail.com

Received 9 March 2004

Revised 9 March 2004

Accepted for publication 9 March 2004

REFERENCES

- 1 **Moreno Gallego A**, Aguayo J, Flores B. Ultrasonography and Computed Tomography reduce unnecessary surgery in abdominal Rectus Sheath Haematomas. *Br Jnl Surg* 1997;**84**:1295–1297.
- 2 **Casey RG**, Mahmoud M, Carroll K, et al. Rectus Sheath Haematoma: An Unusual Diagnosis. *Ir Med Jnl* 2000;**93**(3):90–92.
- 3 **Tsapatsaris NP**. Low dose heparin. A cause of haematoma of Rectus Abdominis. *Arch Intern Med* 1991;**151**:597–599.
- 4 **Martinez Jabaloyas J**, Planells MV. Haematoma of the Rectus Abdominis Muscle. *Rev Esp Enferm Dig* 1993;**83**:213–14.
- 5 **Titone C**, Lipsius M. Spontaneous haematoma of the Rectus Abdominis muscle: critical review of 50 cases with emphasis on early diagnosis and treatment. *Surg* 1972;**72**:568–72.
- 6 **Chatzipapas IK**, Magos AL. A simple technique of securing inferior epigastric vessels and repairing the rectus sheath at laparoscopic surgery. *Obstet Gynaecol* 1997;**90**:304–6.
- 7 **Levy JM**, Gordon HW. Gelfoam Embolization for control of bleeding from rectus sheath haematoma. *AJR Am J Roentgenol* 1980;**135**(6):1283–4.

Accidental human poisoning with a veterinary tranquilliser

F H Cummins

Emerg Med J 2005;**22**:524–525

Detomidine is an alpha-2 adrenoceptor agonist drug, which is used in veterinary medicine for sedation of large animals.^{1–4} It is highly potent and has sedative and analgesic properties.^{1,2} This paper reports a case of accidental human poisoning with this drug.

CASE REPORT

A 35 year old farmer was preparing to sedate a bull in order to pare its hooves. No vet was present. The farmer had 5 ml of Domosedan (detomidine hydrochloride 10 mg/ml) in a 5 ml syringe with a 21G×1.5" (0.8×40 mm) needle attached. The bull moved as the farmer was about to give this medication and he injected himself in the thenar eminence of his left hand. He later said that he had been holding the syringe by the barrel rather than the plunger and he did not think he had injected a significant volume of the drug. He claimed that he could not recall how he came to possess the drug. He had no relevant medical history, was on no medication, and had last drunk alcohol 4 days previously.

Within 10 minutes of this accident, the farmer began to feel drowsy, dizzy, and relaxed. His companions noted that he was not performing his tasks normally. When questioned, he responded in a slurred and drunken manner. His gait became unsteady. He was carried to a vehicle and taken to the emergency department.

On arrival he was noted to be drowsy, with slurred speech, and a passively euphoric state, but his Glasgow Coma Score (GCS) was 15. His heart rate was 44 beats/min and his blood pressure 106/48 mmHg. A small superficial puncture wound was noted on the left thenar eminence. No other abnormality was apparent on examination. His ECG showed a sinus bradycardia with no evidence of heart block or ischaemia.

Peripheral intravenous access was obtained and an infusion of 0.9% sodium chloride was started. Two boluses of atropine 500 µg were given. Within minutes, a sustained rise in heart rate and blood pressure was noted, but the patient remained significantly drowsy. He was given 2 litres

of intravenous saline over 2 hours. TOXBASE (an online poisons database; www.spib.axl.co.uk) was consulted. The patient was observed overnight with cardiac monitoring but received no further medications. Over the next 16 hours he regained full consciousness and his pulse and blood pressure remained normal. He was discharged home.

DISCUSSION

Detomidine (trade names Domosedan and Dormosedan) is used for sedating horses and other animals to facilitate examination and surgical procedures.^{1,2} Detomidine causes a bradycardia with blood pressure initially raised and then normal or low, reduced cardiac output, and slowing of intracardiac conduction with partial sinoatrial and atrioventricular block. Respiratory depression and diuresis may occur.^{1,2} Detomidine potentiates the actions of other sedative and analgesic drugs. It has similar effects to clonidine.^{5–7}

TOXBASE (www.spib.axl.co.uk/toxbase/poisons%20information/d/detomidine.htm) mentions that a dog that chewed a vial of detomidine had salivation, sedation, collapse, hypotension, bradycardia, arrhythmias, and coma, which lasted for 18 hours. The treatment advised by TOXBASE in human poisoning is supportive, with observation for at least 4 hours, or longer if symptomatic, and monitoring of blood pressure and cardiac rhythm. Hypotension should be corrected by raising the foot of the bed and by giving intravenous fluids, and vasopressors should be considered in severe cases. Bradycardia may require treatment with atropine and rarely with cardiac pacing. Severe and persistent hypertension may be treated with phentolamine.

The only previous report of detomidine poisoning in humans is a single case of deliberate injection of detomidine 50 mg and butorphanol 100 mg in a 36 year old man.⁸ Butorphanol is an opioid drug for which the antidote is naloxone.⁹ The patient presented with a GCS of 6 and required a continuous infusion of naloxone, but his heart rate never fell below 70 beats/min and his blood pressure never below 110/80 mmHg. He made a full recovery.

The manufacturers of detomidine are aware of only one other case of human exposure to this drug (Pfizer, personal communication). In this case, the farmer rapidly developed sedation and had bradycardia and hypotension but recovered with the treatment advised by TOXBASE.

Detomidine is a potent drug and the dose recommended for sedation and analgesia in animals is 20 to 40 µg/kg that is, 0.2–0.4 ml/100 kg.¹ In this case the syringe contained 5 ml, which would have been sufficient for an animal of at least 1500 kg. It was fortunate that only a small amount was apparently injected. The farmer believed that only the drug that was in the needle was actually injected, but this could not be confirmed. A larger volume might have caused catastrophic cardiovascular collapse.

Detomidine should only be used by veterinary surgeons. The unregulated use of such potent drugs by non-veterinary personnel is hazardous. In this case, the farmer was unwilling to say how he came to have this restricted medication, and this raises issues about the availability of this and other veterinary drugs. One might wonder whether some fatal farmyard accidents could result from unrecognised exposures to potent veterinary medications.¹⁰

Competing interests: none declared

Correspondence to: F H Cummins, Cork University Hospital, Cork, Ireland; cumminsfergal@hotmail.com

Accepted 8 December 2003

REFERENCES

- 1 England GC, Clarke KW. Alpha 2 adrenoceptor agonists in the horse - a review. *Br Vet J* 1996;**152**:641–57.
- 2 Pfizer. *Domosedan data sheet*. www.pfizer.com/ah/vet/tref/merch/3698372.html.
- 3 Yamashita K, Tsubakishita S, Futaok S, et al. Cardiovascular effects of medetomidine, detomidine and xylazine in horses. *J Vet Med Sci* 2000;**62**:1025–32.
- 4 Atkinson MW, Hull B, Gandolf AR, et al. Repeated chemical immobilization of a captive greater one-horned rhinoceros (*Rhinoceros unicornis*), using combinations of etorphine, detomidine, and ketamine. *J Zoo Wildl Med* 2002;**33**:157–62.
- 5 Seger DL. Clonidine toxicity revisited. *J Toxicol Clin Toxicol* 2002;**40**:145–55.
- 6 Gitter MF, Cox R. Clonidine toxicity in an adolescent patient. *J Miss State Med Assoc* 2000;**41**:757–9.
- 7 Frye CB, Vance MA. Hypertensive crisis and myocardial infarction following massive clonidine overdose. *Ann Pharmacother* 2000;**34**:611–15.
- 8 Reid FM, Tracey JA. Parenteral exposure to detomidine and butorphanol. *J Toxicology Clin Toxicol* 1994;**32**:465–9.
- 9 Reynolds JEF. *Martindale, - the extra pharmacopoeia*, 30th ed. London: The Pharmaceutical Press, 1993:1069.
- 10 Pickett W, Hartling L, Brison RJ, et al. Fatal work-related farm injuries in Canada, 1991–1995. Canadian Agricultural Injury Surveillance Program. *CMAJ* 1999;**160**:1843–8.

Unusual abdominal complication of rib fracture: a case report and review of literature

T M Grandhi, S M A El-Rabaa

Emerg Med J 2005;**22**:525–526

Rib fracture is known to cause a variety of intrathoracic and intra-abdominal injuries. It is associated with intra-abdominal solid organ injuries, but rarely is itself a cause of hollow viscus perforation. We report a case of a woman who sustained a blunt injury during which a segment of fractured rib penetrated through the diaphragm and perforated the stomach.

CASE REPORT

A 33 year old woman was brought to the accident and emergency department at West Cumberland Hospital following an accident in which she was crushed by a grabber from behind, sustaining blunt injuries to the chest and abdomen. She complained of pain in the chest and abdomen and vomited once. She denied any respiratory, cardiovascular, or gastrointestinal symptoms. She was conscious, coherent, and haemodynamically stable, with normal pulse and blood pressure. Her Glasgow coma score was 15. Examination revealed tenderness and subcutaneous emphysema in the left lower chest with good air entry bilaterally. Examination of the abdomen revealed a laceration measuring 5 cm in length, with tenderness and guarding in the left upper quadrant.

Dipstick examination of the urine showed moderate amounts of blood. Full blood count and serum biochemistry was normal. Chest x ray showed fractures of the eighth and ninth ribs on the left side, and confirmed local subcutaneous emphysema in the soft tissues overlying the fractures. There was no evidence of pneumo/haemothorax or pneumoperitoneum. A computerised tomography (CT) scan of the abdomen was performed, which showed normal solid abdominal viscera with intact spleen and

well perfused kidneys. There was some free intraperitoneal gas and fluid. The CT scan again confirmed rib fractures and local emphysema close to the splenic flexure, suggesting colonic perforation. The stomach was distended and appeared intact. Major vessels were intact. Minor posterior atelectasis was noted at the base of the lungs, but there was no pneumothorax or significant pleural effusion. CT scan also showed a fracture of the left transverse process of L4 vertebrae with intact vertebral body and psoas swelling.

In the light of the CT scan, exploratory laparotomy was performed, which revealed copious amounts of bilious free fluid in the abdomen. Two perforations close together were noted in the posterior wall of the body of the stomach. A large piece of the fractured rib, which had penetrated the diaphragm, was seen protruding through the retroperitoneum below the spleen. There was a 3 cm tear in the transverse mesocolon, and a breach in the peritoneum overlying the left lumbar transverse process close to the ureter. A laceration in the left psoas muscle was noted. The remaining intra-abdominal viscera, including the small and large bowel, liver, spleen, pancreas, kidneys, and ureter, were normal. The area with the perforations in the posterior wall of the stomach was excised, and the stomach closed with linear stapler. The peritoneal cavity was lavaged with copious amounts of normal saline, and the abdomen was closed using the mass closure technique after placing drains in the left subphrenic space and pelvis. The laceration over the abdomen was closed with interrupted nylon sutures. A prophylactic chest drain was inserted in the left fifth intercoastal space in the mid-axillary line.

The patient had an uneventful recovery from surgery. The chest drain was removed with no further complications. The fracture of the lumbar transverse process was managed conservatively with analgesics, physiotherapy, and mobilisation. She was symptom free at follow up.

DISCUSSION

Fracture of the ribs can cause a variety of intrathoracic and intra-abdominal complications. Apart from the usual complications of surgical emphysema and pneumothorax, it has also been reported to cause mediastinal emphysema and pneumopericardium.¹ During blunt injuries, lower rib fractures are associated with intra-abdominal, solid organ injury, in particular to the liver and spleen, but the fractured segment itself is rarely a cause of intra-abdominal hollow viscus injury. Gastric perforation is a very rare complication of fractured rib, and to our knowledge, has not previously been reported in the English language literature, although a similar case with multiple rib fractures that resulted in a segment of the fractured rib penetrating through the diaphragm to the stomach was reported in the Japanese literature.²

Imaging investigations can at times be misleading, as in our present case. The initial chest x ray did not reveal either pneumothorax or pneumoperitoneum. The CT scan did not show pneumothorax; it suggested a colonic rather than gastric perforation due to a presumed intact and distended stomach and the proximity of rib fractures to this splenic flexure. In our case, a segment of fractured rib had

penetrated through the diaphragm and perforated the stomach.

CONCLUSION

Gastric perforation is an interesting and a rare complication of rib fracture. As the clinical examination and investigations can be misleading, there should be a high index of suspicion of intra-abdominal organ injury, particularly in patients with lower rib fractures. This case emphasises the importance of thorough exploration of all intra-abdominal organs during laparotomy, and the physician should not be falsely reassured by the imaging investigations.

Authors' affiliations

T M Grandhi, Queen Elizabeth Hospital, King's Lynn, Norfolk, UK
S M A El-Rabaa, Kettering General Hospital, Kettering, Northants, UK
Competing interests: none declared

Correspondence to: Mr S M A El-Rabaa, Consultant Surgeon, Kettering General Hospital, Kettering, Northants NN16 8UZ, UK; saleem.el-rabaa@kgh.nhs.uk

Accepted 8 December 2003

REFERENCES

- 1 Anderson RH, Garfinkel HA. Complications of fractured ribs. *Br J Clin Pract* 1967;21:419-21.
- 2 Inoue S, Tezuka N, Sawai S, et al. Intra abdominal organ injury due to blunt chest trauma – report of two cases. *Jap J Thoracic Cardiovasc Surg* 1998;46:902-5.

Coincidental deficiency of the posterior arch of the atlas and thalassaemia minor: possible pitfalls in a trauma victim

M H Schrödel, V Braun, E Stolpe, H Hertlein

Emerg Med J 2005;22:526-528. doi: 10.1136/emj.2003.006759

Congenital abnormalities of the cervical spine are rare findings in trauma victims. Deficiency of the posterior arch of the atlas and coincidental thalassaemia minor are even more unusual. This case report is about a young female trauma victim with both abnormalities, a combination that has previously not been described in literature. The classification, as proposed by Currarino *et al* in 1994, and the importance of being aware of these abnormalities are discussed.

Fractures of the first cervical vertebra are infrequent findings in trauma victims. Furthermore, congenital abnormalities of the craniocervical junction are incidental findings on routine x ray examinations of the cervical spine. However, in trauma examination, some deficiencies may result in erroneous interpretation.^{1 2}

Thalassaemia, which belongs to a group of chronic, familial haemolytic anaemias, is common among the populations of the countries bordering the Mediterranean Sea. It is characterised by abnormality in the balance of production of the α and β -haemoglobin chains. Thalassaemia minor is asymptomatic in most cases, so the resultant anaemia could be yet another possible pitfall in the emergency management of trauma, as it may mimic major blood loss.

We report a 16 year old girl with suspected traumatic injury of the cervical spine who had complete absence of the posterior arch of the atlas as confirmed by magnetic resonance (MR) imaging and, in addition, as a further diagnosis, thalassaemia minor. To our knowledge, it is the first report of the co-occurrence of these two congenital abnormalities.

CASE REPORT

A 16 year old girl was cycling on a staircase on her bike when she fell on the left side of her face and suffered multiple scratches. On admission, she complained of neck pain. She had slightly impaired active flexion, extension, and rotation of the head, primarily due to the pain. There were no neurological deficits. A routine blood sample revealed haemoglobin 9.8 mg/dl. At first major injury was suspected, but on clinical examination this was not confirmed.

There was a void evident in the posterior part of the craniocervical junction in the plain x rays of the cervical spine (fig 1). Initially, fracture of the atlas was suspected, although no fragment was seen. A detailed history revealed no known cervical abnormalities but a kind of Mediterranean anaemia and that the patient's father originated from Italy.

The patient was admitted for further clinical observation and examination. Additional MR imaging of the cervical spine revealed a congenital deficiency of the posterior arch of



Figure 1 Lateral x ray of the cervical spine showing a complete absence of the posterior arch of the atlas.

the atlas without a posterior tubercle and ruled out a fracture or any other structural injury (fig 2). Laboratory investigations, including haemoglobin electrophoresis and blood smear revealed the following results (laboratory reference values in parenthesis): haemoglobin 9.8 mg/dl (14.0–18.0); MCH 29 pg (29.0–34.0); MCV 85 fl (86.0–100.0); serum iron 130 µg/dl (40–130); HbA₂ 6.3% (2–3%); HbF 3.1% (0.8–2%); HbA₁ 90.6% (95–98%). Thus the presence of a hypochromic, microcytic anaemia led to a diagnosis of β -thalassaemia.

DISCUSSION

Perichondral ossification of the posterior arch of the first vertebral body starts from two centres in the lateral masses and proceeds to the midline.³ Fusion normally occurs at three to five years of age, and incomplete fusion persists in 3–5%.⁴ Occasionally, ossification starts from a separate posterior centre, fusing with the lateral masses to form the posterior arch and leading to the development of a posterior tubercle.^{5–7} Larger defects of the posterior arch are rare; some authors have reported an incidence of less than 1%. The underlying embryological basis is commonly believed to be a local mesenchymal defect leading to lack of chondrification.^{7–8}

Currarino *et al*⁸ proposed an anatomical classification of the defects of the posterior atlas, modified from Von Torklus and Gehle⁹:

- Type A—failure of the posterior midline fusion of the two hemiarches
- Type B—unilateral cleft
- Type C—bilateral clefts
- Type D—total absence of the posterior arch with a persistent posterior tubercle
- Type E—total absence of the posterior arch with missing posterior tubercle.

According to this classification, the present patient has a rare type E abnormality. A hypertrophic spinous process of the axis (C2) is described occasionally in type E abnormalities. Our patient also had this (fig 1).

Hereditary factors may contribute to these anomalies, but the frequency of heredity is not known. Motatenau *et al*⁹ and



Figure 2 Magnetic resonance scan of the atlas—missing posterior arch.

Currarino *et al*⁸ reported an affected mother and daughter, and mother and son, respectively. Our patient's father had thalassaemia minor as well as the patient herself, but we were unable to obtain informed consent for further x ray examination of the cervical spine or laboratory examination.

In most reports, the lesion was discovered incidentally in asymptomatic patients.^{10–11} In others, the patients had complained of neck discomfort and x ray examination of the cervical spine had revealed incomplete arches.^{7–12–14} Sporadic neurological deficits have been described. To our knowledge, however, no permanent neurological deficits such as paralysis have been reported. Richardson *et al*¹⁵ reported a patient with an incomplete absence of the posterior arch who had intermittent quadriparesis after hitting his head against a car door, and who recovered completely with resolution of any neurological symptoms. Thalassaemia major (Cooley's anaemia) sometimes leads to bony abnormalities such as "hair on end" appearance of the skull bone, but no cervical spine abnormalities have been reported so far.

CONCLUSION

It is essential to be aware of both conditions—deficiency of the posterior arch of the atlas and thalassaemia minor—as both anomalies may lead to false diagnosis, especially in trauma victims. Of course, the aetiopathogenetic relation cannot be proved in this case. When treating trauma victims it is important to have both abnormalities in mind, in order not to mistake slightly injured for severely injured patients.

Competing interests: none declared

Correspondence to: M H Schrödel, KH Munich-Harlaching, Sanatoriumsplatz 2, Munich, Germany, 81545; schroedel@unfallchirurgie-muenchen.org

Accepted for publication 24 November 2003

REFERENCES

- 1 Vogel H, Schöttle H, Tödt HC. Atlasbogenaplasie. *Röntgen-Blätter* 1983;36:160–1.
- 2 Brückner L. Doppelseitige dorsale Atlasbogenaplasie—Anlaß zur Fehleinschätzung nach Trauma. *Beitr Orthop Traumatol* 1983;30:576–8.

- 3 Childers JC, Wilson FC. Bipartite atlas—review of the literature and report of a case. *J Bone Joint Surg* 1971;**53-A**, 3:578–82.
- 4 Friedman MB, Jacobs LH. Case report: computed tomography of congenital clefts of the atlas. *Comput Radiol* 1985;**9**, 3:185–7.
- 5 Von Torklus D, Gehle W. *Die obere Halswirbelsäule*. Stuttgart: Thieme, 1975.
- 6 Geens JG, Schuur KH. A rare developmental variant of the atlas. *Eur J Radiol* 1985;**5**:12–13.
- 7 Hierholzer J, Isalberti M, Hosten N, et al. A rare, complex developmental anomaly of the atlas: embryological and radiological considerations. *Neuroradiology* 1999;**41**:901–3.
- 8 Currarino G, Rollins N, Diehl JT. Congenital defects of the posterior arch of the atlas: a report of seven cases including an affected mother and son. *AJNR Am J Neuroradiol* 1994;**15**:249–54.
- 9 Motateanu M, Gudinchet F, Sarraj H, et al. Case report 665. *Skeletal Radiol* 1991;**20**:231–2.
- 10 Banki Z. Atlasbogenaplasie ventral, Dorsales einseitiges Bogenrudiment. *Fortschr Röntgenstr* 1981;**135**:741–2.
- 11 Le Minor JM, Rosset P, Favard L, et al. Fracture of the anterior arch of the atlas associated with a congenital cleft of the posterior arch. *Neuroradiology* 1988;**30**:444–6.
- 12 Lipson SJ, Mazur J. Anteroposterior spondyloschisis of the atlas revealed by computerized tomography scanning—a case report. *J Bone Joint Surg Am* 1978;**60**:1104–5.
- 13 Hosalkar HS, Gerardi JA, Shaw BA. Combined asymptomatic congenital anterior and posterior deficiency of the atlas. *Pediatr Radiol* 2001;**31**:810–13.
- 14 Schulze PJ, Buurman R. Absence of the posterior arch of the atlas. *Am J Radiol* 1980;**134**:178–80.
- 15 Richardson EG, Boone SC, Reid RL. Intermittent quadriparesis associated with a congenital anomaly of the posterior arch of the atlas. *J Bone Joint Surg* 1975;**57-A**:853–4.

Primary gradient defect distal renal tubular acidosis presenting as hypokalaemic periodic paralysis

P A Koul, A Wahid, F A Bhat

Emerg Med J 2005;**22**:528–530. doi: 10.1136/emj.2003.004465

A 45 year old man presented with recurrent hypokalaemic paralysis. Laboratory investigations revealed renal tubular acidosis as the cause of the hypokalaemia, and dynamic tubular studies suggested a gradient defect as the underlying cause. The patient had associated dextrocardia. To our knowledge, this is the first report of this condition

One of the important presentations of distal renal tubular acidosis (DRTA) is recurrent hypokalaemic weakness, which can be life threatening.^{1,2} DRTA has been reported to cause periodic hypokalaemic paralysis, and the defect is usually secretory, characterised by an inability of the tubular cells to secrete H⁺ ions, resulting in acidosis and alkaline urine.^{1–4} However, amphotericin B has been known to cause DRTA due to a permeability defect, where the inability to lower urinary pH despite unimpaired H⁺ secretion is attributable to H⁺ leakback, which is more evident when the tubular urine is acidic.^{5,6} One study reported an infant with a spontaneous metabolic acidosis induced by a gradient defect;⁷ however, to our knowledge, no case of hypokalaemic periodic paralysis caused by a gradient defect DRTA has been reported previously. We report a case of hypokalaemic periodic paralysis in which the renal tubular defect was subsequently found to be due to an underlying gradient defect.

CASE REPORT

A 45 year old man was admitted with a 1-day history of lower limb weakness that had progressed slowly to involve his upper limbs over a period of 12 hours. He had received an insect bite on his right thigh 4 days previously, which had resulted in local cellulitis for which he was receiving cefuroxime and nimuselide. There was no history of intake of any diuretics, excessive sweating, gastrointestinal illness, or exposure to excessive cold or heat. The patient denied any tingling, paresthesias, weakness of the cranial nerves or respiratory muscles, or any sphincteric disturbance. He had

experienced three similar episodes in the past, each being managed in the hospital by oral potassium chloride.

Clinical examination revealed a pulse rate of 96 beats/min, a blood pressure of 130/80 mmHg, a respiratory rate of 23 breaths/min, and temperature of 37.5°C, with grade 3 motor weakness of the upper limbs and grade 0–1 weakness of the lower limbs. Reflex, sensation, and sphincter responses were normal. The patient had non-localisation of the cardiac impulse, cardiac dullness from the right third space in the midclavicular line to the midsternal line, but stronger heart sounds on the right side of the chest (findings consistent with dextrocardia). He had resolving cellulitis of the left inguinal region, and the rest of the general and systemic examination was normal.

Haemoglobin was 132 g/l, leucocytes 5.3 × 10⁹/l with a normal differential, platelet count 157 × 10⁹/l, serum urea nitrogen 6.33 mmol/l, creatinine 70.7 mmol/l, glucose 4.77 mmol/l, proteins 78 g/l, and albumin 40 g/l. Serum alanine transferase was 86 IU/l (normal 0–40), aspartate transferase 75 IU/l (normal 0–35), creatinine kinase 1941 U/l (normal 50–195), lactate dehydrogenase 555 U/l (normal 250–450), sodium 130 mmol/l (normal 135–145), potassium 2.9 mmol/l (normal 3.5–5.5), and chloride 112 mmol/l (normal 98–108). Arterial pH was 7.41 (normal 7.38–7.44), pCO₂ 26.5 mmHg (normal 35–45), and bicarbonate 15.3 mmol/l (normal 22–28). Chest radiograph and electrocardiogram were consistent with dextrocardia. The patient was started on potassium chloride and recovered over a period of 24 hours.

Dynamic tubular function testing

Urinary pH was 7.0. In order to test renal acidification after induced academia, ammonium chloride (0.1 g/kg body weight) was administered, during which the blood pH increased to 7.30 but the urinary pH continued alkaline (pH>6.5), suggesting a defect in distal tubular acidification. Serum osmolality was 286 mOsmol/kg and urinary osmolality 379 mOsmol/kg; the osmolality did not change after administration of pitressin, suggesting hyposthenuria.

A bicarbonate infusion was administered at the rate of 3 ml/min/kg. At an induced blood pH of 7.76, urinary (U)

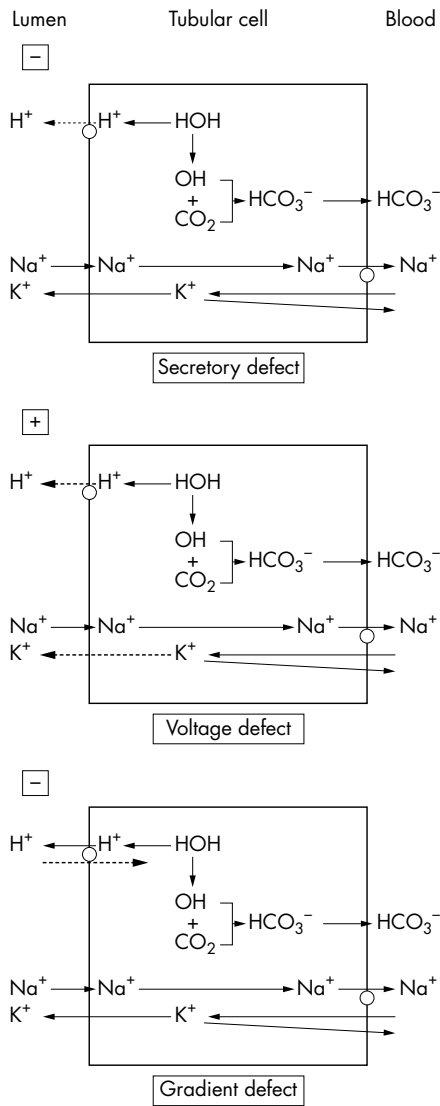

Figure 1 Mechanisms underlying the main types of defects in distal renal tubular acidosis. In the secretory defect there is a failure of H⁺ ion secretion even when conditions are favourable for its secretion. In the "voltage defect", the nephron is unable to generate and maintain a negative intratubular potential difference as a result of defective sodium delivery or transport, resulting in a reduced secretion of both H⁺ and K⁺ ions. In the gradient defect there is an inability to create a steep H⁺ ion gradient across the tubule owing to leakback of secreted H⁺ ions.

pCO₂ was 71.2 mm Hg, and blood (B) pCO₂ was 30.4 mm Hg, giving a U-B pCO₂ of 40.8 mm Hg (a normal response against a low value of <20 in DRTA). Urinary sodium was 188 mmol/l and chloride 124 mmol/l. Fractional excretion of bicarbonate was 3.2%. In order to test the proton secretory ability of the distal nephron, acetazolamide (15 mg/kg) was administered to induce maximum urinary alkalinisation. Two hours after administration, urinary pH increased to 7.65, urinary bicarbonate was 190 mmol/l, urinary pCO₂ was 56.8, and U-B pCO₂ was 29.7, indicating an intact proton secretory ability in the distal nephron. The dynamic studies suggested a gradient type of distal acidification defect.

Furosemide 60 mg was given in order to test the acidification at an increased sodium delivery. Urinary pH decreased to 4.2, suggesting an intact ability of the nephron to acidify urine after furosemide, arguing strongly in favour of a "gradient defect".

Ultrasound examination of the abdomen and intravenous urogram was normal. Serum antibodies to nuclear antigen, latex agglutination test, and antibodies to smooth muscle, parietal cell, and mitochondrial antigen were not detected. Serum levels of copper, caeruloplasmin, rennin, and aldosterone were normal, as was urinary excretion of calcium, phosphate, urate, protein, and aminoacids. An upper gastrointestinal tract endoscopy for dyspeptic symptoms revealed anatomy consistent with situs inversus. All family members of the patient denied a similar history and tested negative for any urinary acidification defect.

DISCUSSION

Gradient defect was for many years postulated to be the primary mechanism underlying DRTA.⁷ However, an inability to increase urinary pCO₂ was subsequently demonstrated, implying a defect in proton secretion.^{8,9} A reliable measure of this was found to be the difference in urinary and blood pCO₂ (urine minus blood levels); in DRTA the value is low. However, in DRTA induced by amphotericin B, there is a typical gradient defect, characterised by the ability of the tubule to increase urinary pCO₂ after maximum alkalinisation.^{6,7}

The diagnosis of DRTA in our patient was made from his inability to acidify urine in the face of metabolic acidosis. Various mechanisms underlying the common forms of DRTA are shown in fig 1. Ability to increase urinary pCO₂ after maximum alkalinisation and to decrease urinary pH after giving furosemide strongly argue in favour of a gradient defect in our patient, rather than a primary H⁺ ion defect, where there is an inability to increase urinary pCO₂ following alkalinisation of urine. Such a gradient defect is similar to that induced by amphotericin B. Associated hypokalaemia in our case suggested a generalised permeability defect involving both intercalated and principal cells, as is typically seen with patients receiving amphotericin B. One previously described case of gradient DRTA did not have accompanying hypokalaemia, but hypokalaemia induced paralysis was the primary presentation in our case. We are unaware of a similar report in the literature.

Recent insights into the molecular understanding of DRTA have unravelled certain genetic mutations associated with the condition, including mutations in the chloride-bicarbonate anion exchanger 1 (AE1) seen in autosomal dominantly transmitted DRTA,¹⁰ ATPB1 in autosomal recessive DRTA associated with sensorineural deafness,¹¹ and H-ATPase in patients with autosomal disease without sensorineural deafness.¹² An increase in U-B pCO₂ has also been postulated to arise from a misdirection of AE1 to the apical membrane of type A intercalated cells in a patient with Southeast Asian ovalocytosis who presented with hypokalaemia, but on dynamic tubular testing was found to have high urinary CO₂ tension with an inability to lower pH with furosemide.¹³

Our patient illustrates that a gradient defect might be the underlying defect in patients with DRTA. Investigating patients with RTA with dynamic tubular studies could unravel the defect in more cases.

Authors' affiliations

P A Koul, A Wahid, F A Bhat, Department of Internal Medicine, SheriKashmir Institute of Medical Sciences, Srinagar, Kashmir, India

Competing interests: there are no competing interests

Correspondence to: Dr Parvaiz A Koul, Department of Internal Medicine, SheriKashmir Institute of Medical Sciences, Soura, Srinagar 190 011, Kashmir, India; parvaizk@rediffmail.com

Accepted for publication 18 June 2003

REFERENCES

- 1 **Koul PA**, Saleem SM, Bhat D. Sporadic distal renal tubular acidosis and periodic hypokalemic paralysis in Kashmir. *J Intern Med* 1993;**233**:463–6.
- 2 **Koul PA**, Wahid A. Recurrent paralysis in a young man. *Lancet* 2000;**355**:1612.
- 3 **Battle D**, Kurtzman NA. Distal renal tubular acidosis: Pathogenesis and classification. *Am J Kid Dis* 1982;**1**:328–44.
- 4 **Kurtzman NA**. Renal tubular acidosis: A constellation of syndromes. *Hosp Pract* 1987;**22**:173–8.
- 5 **DuBose TD Jr**, Calfisch CR. Validation of the difference in urine and blood carbon dioxide tension as an index of distal nephron acidification in experimental models of renal tubular acidosis. *J Clin Invest* 1985;**75**:1116–23.
- 6 **Steinmetz PR**, Lawson LR. Defect in acidification induced in vitro by amphotericin. *Br J Clin Invest* 1970;**49**:596–601.
- 7 **Bonilla-Felix M**. Primary distal renal tubular acidosis as a result of a gradient defect. *Am J Kid Dis* 1996;**27**:428–30.
- 8 **Halperin ML**, Goldstein MB, Haig A, *et al*. Studies on the pathogenesis of type I (distal) renal tubular acidosis as revealed by the urinary pCO₂ tensions. *J Clin Invest* 1974;**53**:669–77.
- 9 **Dubose TD**. Hydrogen ion secretion by the collecting duct as a determinant of the urine to blood pCO₂ gradient in alkaline urine. *J Clin Invest* 1982;**69**:145–56.
- 10 **Karet FE**, *et al*. Mutations in the chloride-bicarbonate exchanger gene AE1 cause autosomal dominant but not autosomal recessive distal renal tubular acidosis. *Proc Natl Acad Sci USA* 1998;**95**:6337–42.
- 11 **Karet FE**, Finberg KE, Nelson RD, *et al*. Mutations in the gene encoding B1 subunit of H⁺-ATPase cause renal tubular acidosis with sensorineural deafness. *Nature Genet* 1999;**21**:84–90.
- 12 **Smith AN**, Skaug J, Choate KA, *et al*. Mutations in ATP6N1B encoding a new kidney vacuolar proton pump 116-kD subunit, cause recessive distal renal tubular acidosis with preserved hearing. *Nature Genet* 2000;**26**:71–5.
- 13 **Kaitwatharachai C**, Vasuvattakul S, Yenchitsomanus P, *et al*. Distal renal tubular acidosis and high urine carbon dioxide tension in a patient with Southeast Asian ovalocytosis. *Am J Kid Dis* 1999;**33**:1147–52.